

KAP long throw multi-jet nozzles



MADÉL®

KAP multi-jet nozzles are designed to be used, in air conditioning, ventilation and heating systems at a temperature differential up to 12° C.

They can be mounted in the wall. **KAP** multi-jet nozzles respond to different functional and architectural requirements thanks to their manually adjustable nozzles in all directions. Depending of the size of the rectangular panel, the integrated nozzles can be of 160, 200, 250 or 315 mm. Thanks to its long throw and flexibility of direction of the air pattern, **KAP** multi-jetnozzles are suitable for air diffusion in all kinds of different architectures. It provides a high induction air rate level, reducing stratification.

KAP multi-jet nozzles represents a vanguard in design of air diffusers. Integrating the jet nozzles into the panel, the outcome is a smooth and homogeneous surface, reducing the visual impact within the interior architectures.



CLASSIFICATION

KAP Manually adjustable multi-jetnozzle.

MATERIAL

Jet nozzles constructed from aluminium and the panel from galvanised steel. The seal of rotation is made from immutable material, classified M1 and F2 as regards fire and smoke safety.

ADDITIONAL ACCESSORIES

IBK Pressed collar saddle for mounting into a visible circular duct.

FIXING SYSTEMS

(T) Visible screws.

FINISHES

M9016 Painted in white similar to RAL 9016.

R9010 Painted in white RAL 9010.

RAL... Painted in other RAL colours.

SPECIFICATION TEXT

Supply and mounting of long throw multi-jet nozzle manually adjustable in all directions series **KAP (T) M9016 dim. LxH** constructed from aluminium and galvanised steel, paint in white **M9016** or another defined by the D.F., fixing by visible screws **(T)**. Manufacturer **MADEL**.

KAP

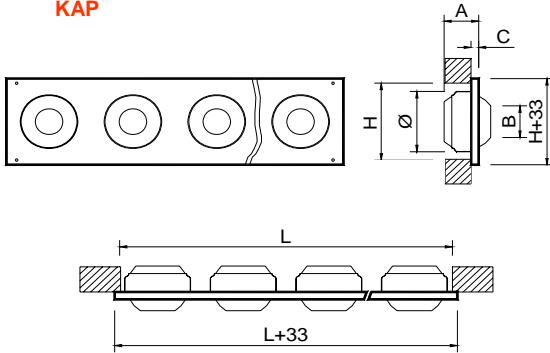

L x H	n	Ø	A	B	C	Ø
500 x 200	2	160	90	80	10	158
800 x 200	3	160	90	80	10	158
1000 x 200	5	160	90	80	10	158
1500 x 200	7	160	90	80	10	158
2000 x 200	9	160	90	80	10	158
500 x 250	2	200	115	102	10	198
800 x 250	3	200	115	102	10	198
1000 x 250	4	200	115	102	10	198
1500 x 250	6	200	115	102	10	198
2000 x 250	7	200	115	102	10	198
800 x 300	2	250	125	130	15	248
1000 x 300	3	250	125	130	15	248
1500 x 300	4	250	125	130	15	248
2000 x 300	6	250	125	130	15	248
800 x 400	2	315	180	166	15	313
1000 x 400	2	315	180	166	15	313
1500 x 400	3	315	180	166	15	313
2000 x 400	4	315	180	166	15	313

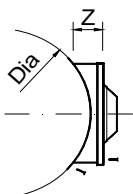

IBK- Dia - L x H	Dia Conducto Dia Duct	Z
IBK- Dia - L x 200	315 - 1600	65
IBK- Dia - L x 250	400 - 1600	75
IBK- Dia - L x 300	500 - 1600	85
IBK- Dia - L x 400	630 - 1600	170



POSITION 1 (0°)

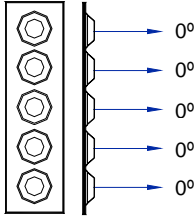

POSITION 2 (22°)

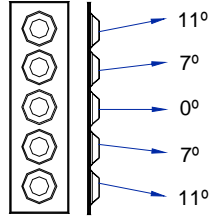

POSITION 3 (45°)

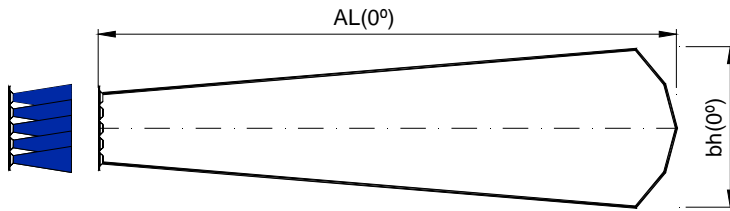
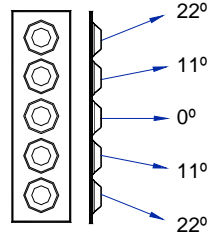

POSITION 1 (0°)
 $AL(0°) = AL$
 $bh(0°) = 0,28 \times AL$

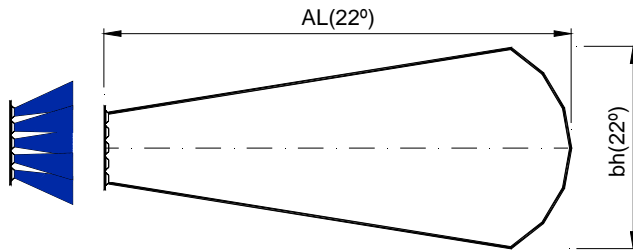

POSITION 2 (22°)
 $AL(22°) = 0,7 \times AL$
 $bh(22°) = 0,68 \times AL$

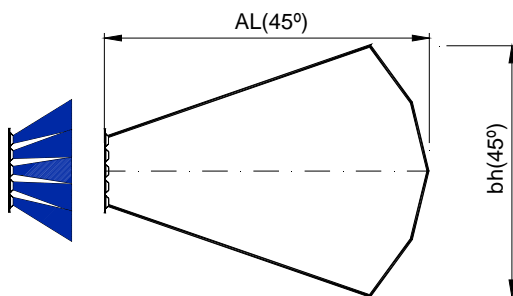

POSITION 3 (45°)
 $AL(45°) = 0,5 \times AL$
 $bh(45°) = 1,15 \times AL$



RECOMMENDED VELOCITY.

	Vfmin m/s	Vfmax m/s
L x H	2,5	12

FREE FACE AREA (m²).

L x H		Afree m ²	Qmin m ³ /h	Qmax m ³ /h
500 x 200	5 x 2	0,01	90	432
800 x 200	8 x 2	0,015	135	648
1000 x 200	10 x 2	0,025	225	1080
1500 x 200	15 x 2	0,035	315	1512
2000 x 200	20 x 2	0,045	405	1944
500 x 250	5 x 2,5	0,017	153	734
800 x 250	8 x 2,5	0,025	225	1080
1000 x 250	10 x 2,5	0,034	305	1468
1500 x 250	15 x 2,5	0,051	459	2205
2000 x 250	20 x 2,5	0,059	531	2548

FREE VELOCITY, PRESSURE LOSS AND SOUND POWER LEVEL,
THROW

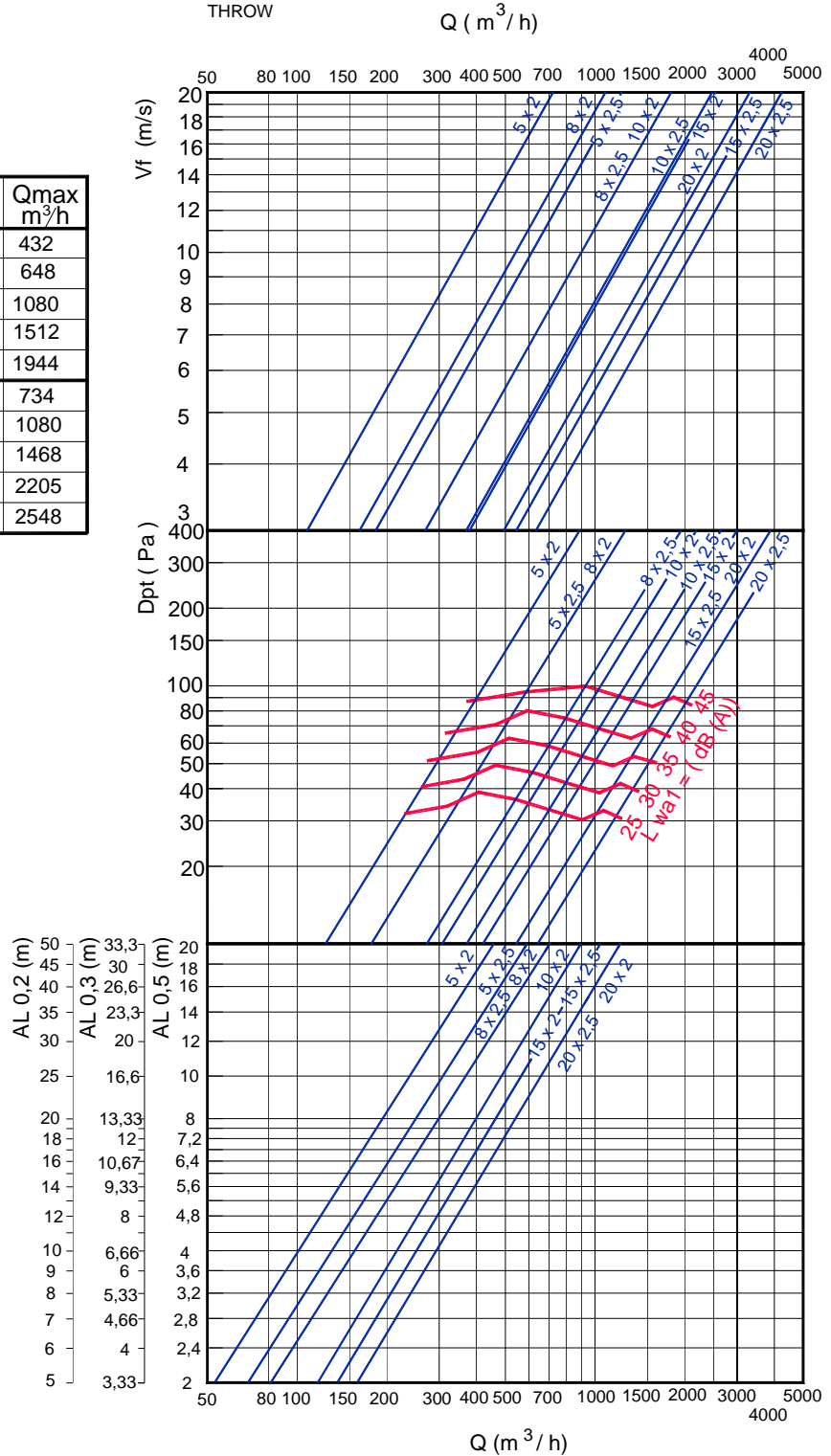



RECOMMENDED VELOCITY.

	Vfmin m/s	Vfmax m/s
L x H	2,5	11

FREE FACE AREA (m2).

L x H		Afree m ²	Qmin m ³ /h	Qmax m ³ /h
800 x 300	8 x 3	0,027	243	1166
1000 x 300	10 x 3	0,040	360	1728
1500 x 300	15 x 3	0,054	486	2332
2000 x 300	20 x 3	0,081	729	3500
800 x 400	8 x 4	0,0452	406	1952
1000 x 400	10 x 4	0,0452	406	1952
1500 x 400	15 x 4	0,0678	610	2928
2000 x 400	20 x 4	0,0904	813	3905

FREE VELOCITY, PRESSURE LOSS AND SOUND POWER LEVEL,
THROW

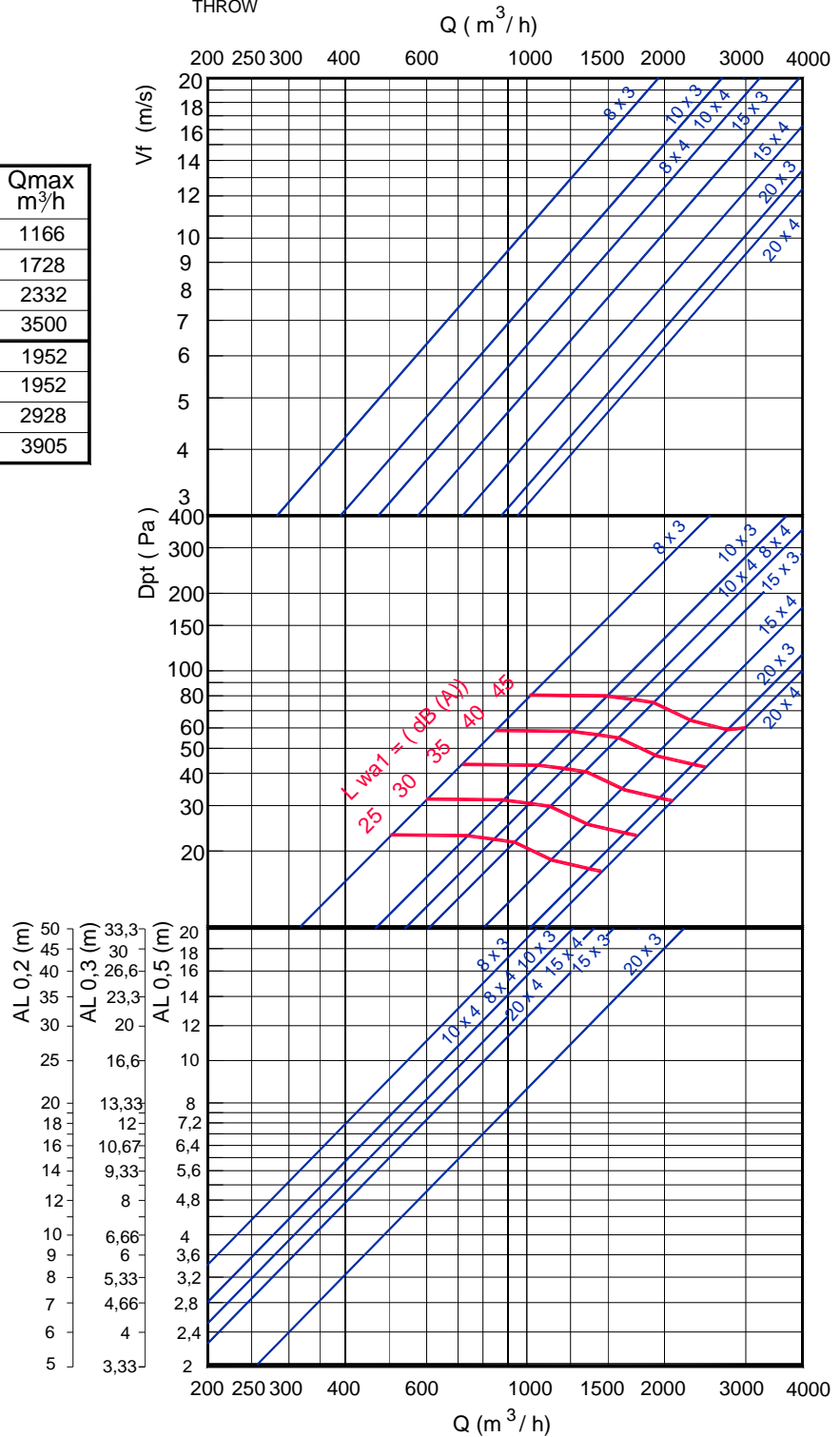

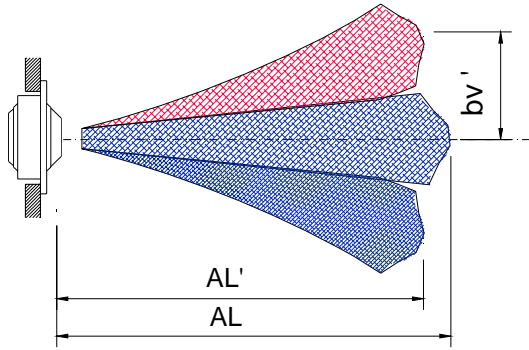

Z1	Z2	Z3	Z4
500x200	500x250	800x300	800x400
800x200	800x250	1000x300	1000x400
1000x200	1000x250	1500x300	1500x400
1500x200	1500x250	2000x300	2000x400
2000x200	2000x250		

CORRECTION FACTOR FOR VERTICAL DIFFUSION (bv) FOR DT (-).

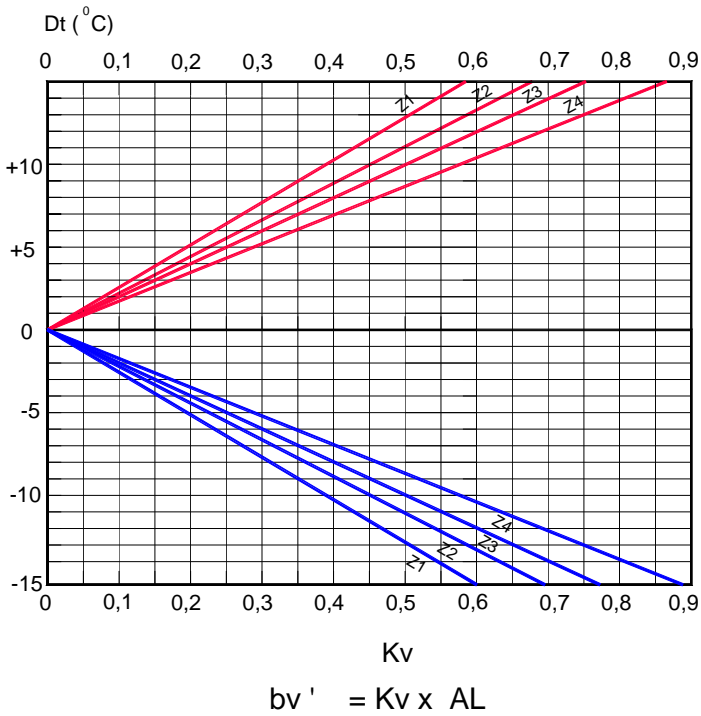

Kv = Correction factor for the vertical diffusion.

CORRECTION FACTOR FOR THROW (L0.2) DT (-).

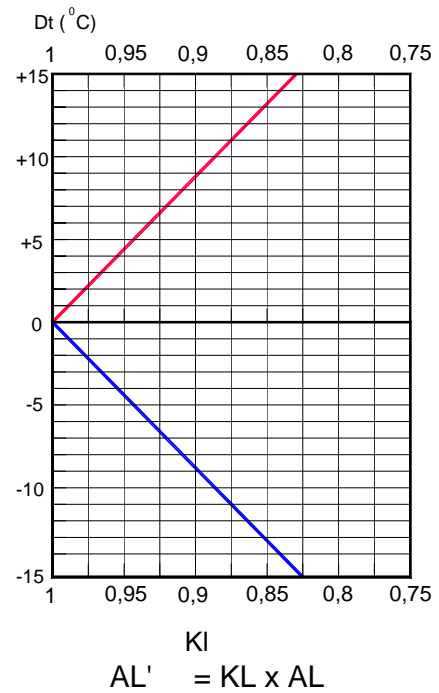

Kl = Correction factor for the throw.